

精密·经济

PS/WPS 系列精密行星减速机

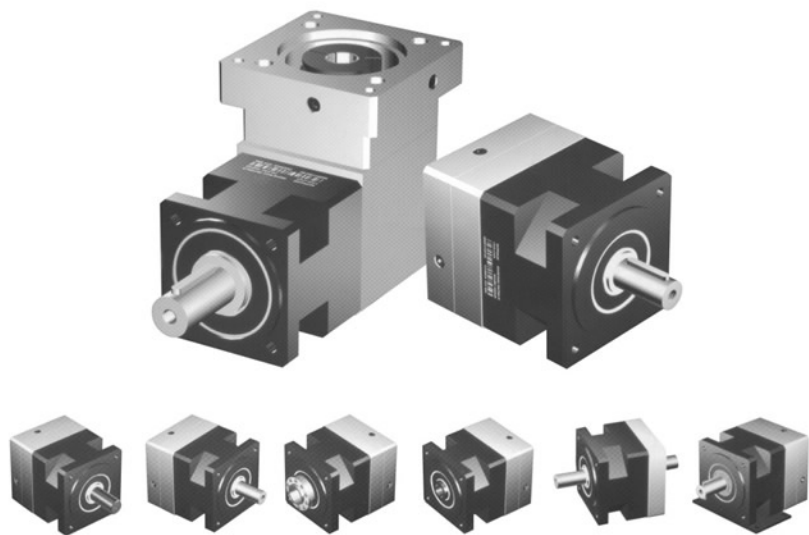

精密·经济

PL(F)/WPL(F)系列精密行星减速机





PL(F)/WPL(F)系列精密行星减速机

Notes of product ordering
减速机选用订购说明

PL/PF series

Precision Planetary Gear Boxes



Ratio/减速比	i=3:1 ~ 10,000:1
Backlash/回程间隙	< 3 arcmin
Output torque/转矩	~1,800N.m
Frame size/机型号	PL40/PF40 ~ PL200/PF215

ordering code 订货代码/型号标注说明

PL(F)	90	L2	32	P2	S2	MOTOR
MODEL 系列代号	SIZE 规格	STAGE 段数/级数	Ratio i 减速比:	Backlash 背隙	Output type 输出安装型式	Input 电机品牌型号
	40, 60	L1: 1段/级	L1: 3, 4, 5, 6, 8, 10	P0: 超精密	S1: shaft 光轴	请告知选用电机品牌、规格型号或者电机输出端尺寸
	80, 120, 140, 160	L2: 2段/级	L2: 9, 12, 15, 16, 18	P1: 精密	S2: shaft with key 单键轴	
	200	L3: 3段/级	L3: 20, 24, 25, 30, 32	P2: 标准	S3: splined shaft 花键轴	
		L4: 4段/级	L4: 36, 40, 48, 64		K1: Hollow shaft 光孔 (外配胀紧套)	
		L5: 60, 64, 72, 75, 80, 90, 100, 120, 144, 150, 160, 180, 200, 240, 256, 288, 320, 384, 512, 600, 800		K2: Hollow with key 单键孔	
					K3: SWline hollow 花键孔	
					T: Special require 用户特殊要求	
					OP 3: Case mounting 减速机箱体装配	
					OP 4: Foot mounting 底座装配	
					Standard connection if no mark 不标注为标准S2型单键实心法兰连接	

WPL/WPF series

Precision Planetary Gear Boxes



Ratio/减速比	i=3:1 ~ 10,000:1
Backlash/回程间隙	< 5 arcmin
Output torque/转矩	~1,800N.m
Frame size/机型号	WPL/PF40 ~ WPL200/PF215

ordering code 订货代码/型号标注说明

WPL(F)	90	L3	64	P2	S2	MOTOR
MODEL 系列代号	SIZE 规格	STAGE 段数/级数	Ratio i 减速比:	Backlash 背隙	Output type 输出安装型式	Input 电机品牌型号
	40, 60	L1: 1段/级	L1: 3, 4, 5, 6, 8, 10	P0: 超精密	S1: shaft 光轴	请告知选用电机品牌、规格型号或者电机输出端尺寸
	80, 120, 140, 160	L2: 2段/级	L2: 9, 12, 15, 16, 18	P1: 精密	S2: shaft with key 单键轴	
	200	L3: 3段/级	L3: 20, 24, 25, 30, 32	P2: 标准	S3: splined shaft 花键轴	
		L4: 4段/级	L4: 36, 40, 48, 64		K1: Hollow shaft 光孔 (外配胀紧套)	
		L5: 60, 64, 72, 75, 80, 90, 100, 120, 144, 150, 160, 180, 200, 240, 256, 288, 320, 384, 512, 600, 800		K2: Hollow with key 单键孔	
					K3: SWline hollow 花键孔	
					T: Special require 用户特殊要求	
					OP 3: Case mounting 减速机箱体装配	
					OP 4: Foot mounting 底座装配	
					Standard connection if no mark 不标注为标准S2型单键实心法兰连接	

PL(F)/WPL(F)系列精密行星减速机



PL(F)/WPL(F) series precision planetary gear boxes torque

PL(F)/WPL(F) 系列精密行星减速机扭矩

Type Stage 型号段数		PL 40	PL 50	PL 60	PL 70	PL 80	PL 90	PL 120	PL 140	PL 160	PL 200	
		PF 40	PF 50	PF 60	PF 70	PF 80	PF 90	PF 115	PF 130	PF 142	PF 215	
Data 性能参数		WPL 40	WPL 50	WPL 60	WPL 70	WPL 80	WPL 90	WPL 120	WPL 140	WPL 160	WPL 200	
		WPF 40	WPF 50	WPF 60	WPF 70	WPF 80	WPF 90	WPF 115	WPF 130	WPF 142	WPF 215	
Nominal output Torque T_{2N} 额定输出扭矩	L1	3:1	8	10	18	22	40	50	125	210	400	1,050
		4:1	18	20	40	45	110	125	260	450	800	1,780
		5:1	16	18	36	41	90	110	230	400	700	1,600
		6:1			22	26	55	65	125	260	550	1,000
		8:1	5	6	15	18	50	55	120	210	450	950
		10:1			12	15	22	32	70	130	210	305
	L2	9:1	8	10	18	22	40	50	125	210	400	1,050
		12:1	18	20	40	45	110	125	260	450	800	1,780
		15:1	16	18	36	41	90	110	230	400	700	1,600
		16:1	18	20	40	45	110	125	260	450	800	1,780
		20:1	18	20	40	45	110	125	260	450	800	1,000
		25:1	16	18	36	41	90	110	230	400	700	1,780
		30:1			36	41	90	110	230	260	700	1,600
		32:1	18	20	40	45	110	125	260	450	800	1,600
		36:1			22	22	55	65	125	260	550	1,780
		40:1	16	20	36	41	90	110	230	400	700	1,600
		48:1			22	22	55	65	125	260	650	1,000
		50:1			20	25	50	67	120	230	450	700
	Nm	64:1	6	6	15	18	50	60	120	210	450	1,000
		48:1	18	20	40	45	110	125	260	450	800	1,780
		60:1	18	20	40	45	110	125	260	450	800	1,780
		64:1	18	20	40	45	110	125	260	450	800	1,780
		75:1	16	18	36	41	90	110	230	400	700	1,600
		80:1	18	20	40	45	110	125	260	450	800	1,780
		90:1	16	18	36	41	90	110	230	400	700	1,600
		100:1	18	20	40	45	110	125	260	450	800	1,780
		120:1	18	20	36	41	110	125	260	450	800	1,780
		125:1	16	18	36	41	90	110	230	400	700	1,600
		150:1	16	18	36	41	90	110	230	400	700	1,600
		160:1	18	20	40	45	110	125	120	450	800	1,780
		180:1	16	18	36	41	90	110	110	400	700	1,600
		200:1	16	18	36	41	90	110	230	400	700	1,600
		240:1			36	41	90	110	230	400	700	1,600
		256:1	18	20	40	45	110	125	260	450	800	1,780
		320:1	16	18	36	41	90	110	230	400	700	1,600
		384:1			22	22	55	65	125	260	550	1,000
512:1	6	6	15	18	50	50	120	210	450	1,000		



PL(F)/WPL(F)系列精密行星减速机

PL(F)/WPL(F) precision planetary gear boxes technical data PL(F)/WPL(F) 系列精密行星减速机性能参数

Type Stage/型号 段数		PL 40	PL 50	PL 60	PL 70	PL 80	PL 90	PL 120	PL 140	PL 160	PL 200				
Data 性能参数		PF 40	PF 50	PF 60	PF 70	PF 80	PF 90	PF 115	PF 130	PF 142	PF 215				
		WPL 40	WPL 50	WPL 60	WPL 70	WPL 80	WPL 90	WPL 120	WPL 140	WPL 160	WPL 200				
		WPF 40	WPF 50	WPF 60	WPF 70	WPF 80	WPF 90	WPF 115	WPF 130	WPF 142	WPF 215				
Max. output torque 最大使用扭矩	N.m	1.5 times T2N					1.5倍额定扭矩								
Emergency stop 故障停止扭矩	N.m	2 times T2N					2倍额定扭矩								
F _{rmax} for 10,000h 向最大力矩 ⁽¹⁾	N	160	185	240	265	400	450	1,240	2,250	3,700	4,800				
F _{amax} for 10,000h 最大轴向力 ⁽¹⁾	N	160	150	220	230	420	430	1,000	1,500	3,500	4,500				
Torsional rigidity 扭刚度	Nm arcmin	0.7	0.7	1.8	1.95	4.7	4.85	11	22	35	55				
Max. input speed 最大输入速度	rpm	10,000	10,000	8,000	8,000	6,000	6,000	6,000	4,500	4,500	2,500				
Average input speed 额定输入速度	rpm	4,500	4,500	4,000	4,000	3,500	3,500	3,500	3,000	3,000	2,500				
Noise 噪音	FS WPS dB(A)	<56	<56	<58	<58	<60	<60	<65	<68	<70	<70				
Average lifetime 平均寿命	h	20,000					10,000								
Efficiency w/ full load 满载效率	η	1段 ≥96%			2段 ≥94%			3段 ≥90%							
Backlash 回程间隙	PL PF	P0 arcmin	L1					<3	<3	<3	<3	<3			
			L2					<5	<5	<5	<5	<5			
			L3					<7	<7	<7	<7	<7			
		P1 arcmin	L1	<14	<14	<5	<5	<5	<5	<5	<5	<5			
			L2	<16	<16	<7	<7	<7	<7	<7	<7	<7			
			L3	<18	<18	<9	<9	<9	<9	<9	<9	<9			
	WPL WPF	P2 arcmin	L1	<20	<20	<14	<14	<8	<8	<8	<8	<8			
			L2	<24	<24	<16	<16	<10	<10	<10	<10	<10			
			L3	<28	<28	<18	<18	<12	<12	<12	<12	<12			
		P0 arcmin	L1					<5	<5	<5	<5	<5			
			L2					<7	<7	<7	<7	<7			
			L3					<9	<9	<9	<9	<9			
P1 arcmin	L1	<16	<16	<7	<7	<9	<9	<9	<9	<9					
	L2	<18	<18	<9	<9	<9	<9	<9	<9	<9					
	L3	<20	<20	<11	<11	<11	<11	<11	<11	<11					
P2 arcmin	L1	<22	<22	<16	<16	<10	<10	<10	<10	<10					
	L2	<26	<26	<18	<18	<12	<12	<12	<12	<12					
	L3	<30	<30	<20	<20	<14	<14	<14	<14	<14					
Moment of inertia 转动惯量 ⁽²⁾	kgcm ²	L1	3:1	0.031	0.031	0.135	0.135	0.77	0.77	2.63	5.83	12.14	251.6		
			4:1	0.022	0.022	0.093	0.093	0.52	0.52	1.79	3.21	7.78	243.0		
			5:1	0.019	0.019	0.078	0.078	0.45	0.45	1.53	3.10	6.07	232.4		
			6:1	0.018	0.018	0.075	0.075	0.42	0.42	1.40	2.85	5.24	205.8		
			8:1	0.017	0.017	0.065	0.065	0.39	0.39	1.30	2.10	4.63	56.80		
			10:1	0.016	0.016	0.063	0.063	0.39	0.39	1.28	1.95	4.60			
		L2	15:1	0.015	0.015	0.039	0.039	0.72	0.72	2.40	3.35	7.47	55.30		
			20:1	0.007	0.007	0.049	0.049	0.35	0.35	1.60	2.73	6.95	52.10		
			25:1	0.007	0.007	0.039	0.039	0.25	0.25	1.40	2.25	6.65	52.10		
			32:1	0.007	0.007	0.038	0.038	0.18	0.18	1.40	2.25	5.81	50.09		
			40:1	0.005	0.005	0.027	0.027	0.18	0.18	1.30	2.25	5.81	50.09		
			64:1	0.005	0.005	0.027	0.027	0.16	0.16	1.30	2.25	5.28	40.75		
	L3	80:1	0.015	0.015	0.039	0.039	0.28	0.28	1.57	2.87	6.85				
		100:1	0.007	0.007	0.016	0.016	0.25	0.25	1.35	2.15	5.70	38.60			
		160:1	0.013	0.013	0.016	0.016	0.18	0.18	1.35	2.10	5.55	36.50			
		200:1	0.005	0.005	0.016	0.016	0.18	0.18	1.30	2.10	5.32	32.85			
		256:1	0.005	0.005	0.016	0.016	0.16	0.16	1.30	2.10	5.21	32.85			
		320:1	0.005	0.005	0.016	0.016	0.16	0.16	1.25	2.10	5.15	30.71			
		512:1	0.005	0.005	0.016	0.016	0.16	0.16	1.20	2.10	5.15	28.85			
		Weight 重量 ⁽²⁾	PL(F)	kg	L1	0.37	0.37	0.93	0.93	2.35	2.35	6.15	11.30	19.00	31
					L2	0.45	0.45	1.15	1.15	2.70	2.70	8.00	13.50	24.00	42
					L3	0.55	0.55	1.35	1.35	3.20	3.20	10.00	15.80	29.00	50
			WPL(F)	kg	L1	0.51	0.51	1.7	1.7	4.4	4.4	12	17	26.5	50
					L2	0.61	0.61	1.9	1.9	5.0	5.0	14	19	29.6	61
L3	0.71				0.71	2.1	2.1	5.5	5.5	16	21	32.6	70		

(1) Means: Allowing radial force and axial force that function in input central place when output speed is 100rpm.

(2) The weight of reducer in this book is approximation, the practical depends on the finished product.

(3) The moment of inertia relates to the ratio, frame, input of shaft and to standard motor shaft, etc.

(1) 注意: 是指输出轴100rpm时, 作用于输出轴中心位置之径向力和轴向力。

(2) 本书减速机重量为近似值, 实际重量以实际产品为准。

(3) 转动惯量与减速比、减速机内部结构、输入输出轴等结构有关, 且随使用条件而变化。



PL40-PL200-OP2 motor mounting dimensions
PL40-PL200-OP2 电机联接型式外形安装尺寸

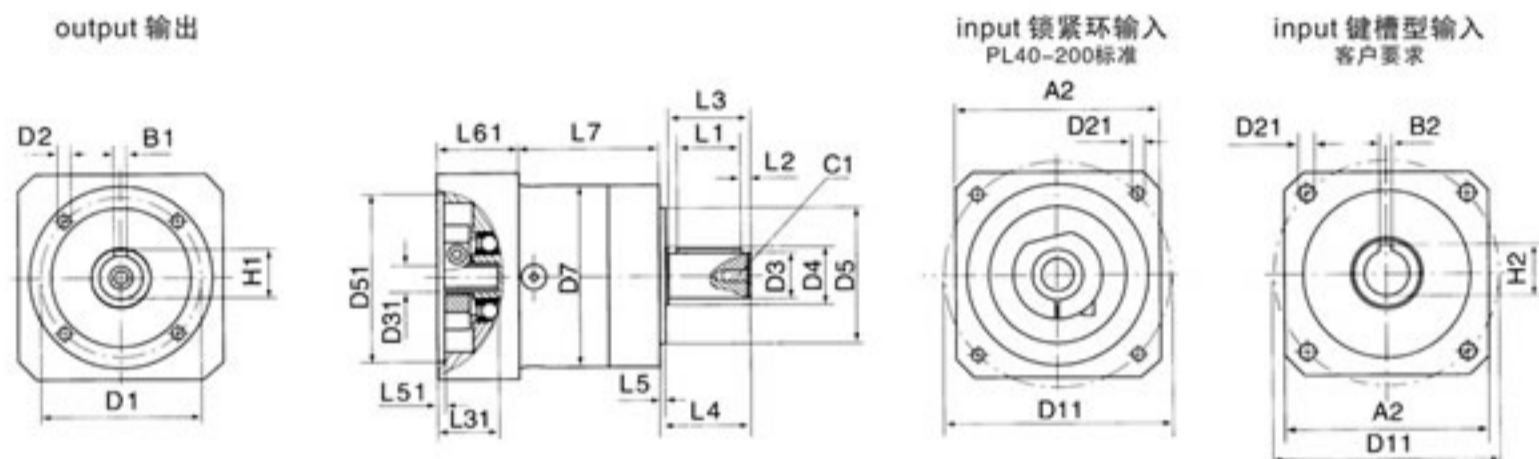

Other shaft 用户可选择的输出类型

output shaft 实轴	S1	Shaft 光轴	S2	shaft with key 单键轴	S3	splined shaft 花键轴	St	special shaft 特殊轴
							According to customers 用户要求制作	
output hollow 孔轴	k1	Hollow 光内孔(外配胀紧套)	k2	hollow with key 单键内孔	k3	splined hollow 花键内孔	kt	special hollow 特殊孔
							According to customers 用户要求制作	

Type Stage 型号段数	PL40			PL50			PL60			PL70			PL80			PL90			PL120			PL140			PL160			PL200				
	1	2	3	1	2	3	1	2	3	1	2	3	1	2	3	1	2	3	1	2	3	1	2	3	1	2	3	1	2	3		
output/输出端尺寸	B1	3			4			5			5			6			6			8			10			12			14			
	C1	M4 × 10			M4 × 10			M5 × 12			M5 × 12			M6 × 16			M8 × 19			M10 × 22			M12 × 25			M12 × 25			M20 × 42			
	H1	11.2			13.5			16			18			22.5			24.5			28			35			43			53.5			
	D1	Φ	34			44			52			62			70			80			100			120			145			184		
	D2	4 ×	M4 × 6			M4 × 9			M5 × 8			M5 × 10			M6 × 10			M6 × 12			M10 × 16			M10 × 16			M12 × 20			M12 × 22		
	D3	Φh6	10			12			14			16			20			22			25			32			40			50		
	D4	Φ	12			15			17			20			25			25			35			40			60			110		
	D5	h7	26			35			40			52			60			68			80			100			130			160		
	D7	Φ	40			50			60			70			80			90			115			140			162			205		
	L1		15			14			25			25			25			25			40			55			65			70		
	L2		2.5			2.5			2.5			3			5			5			5			6			7.5			7.5		
	L3		23			18			30			28			36			36			50			70			80			82		
	L4		26			24.5			35			35			40			46			55			75			87			90		
	L5		2			4			3			5			3			5			4			4			5			6		
	L7 ⁽²⁾		38.5	53	67.5	33.5	49.5	65.5	48	69	86	47.5	67.5	87.5	65	86.5	110.5	55	77	101	74	104	134.5	85	123.5	162	95	134.5	173.5	137	176.5	216
input ⁽¹⁾ /输入端尺寸 ⁽¹⁾	A2	motor			根据电机			motor			根据电机			motor			根据电机			motor			根据电机			motor			根据电机			
	B2	motor			根据电机			motor			根据电机			motor			根据电机			motor			根据电机			motor			根据电机			
	H2	motor			根据电机			motor			根据电机			motor			根据电机			motor			根据电机			motor			根据电机			
	D11	motor			根据电机			motor			根据电机			motor			根据电机			motor			根据电机			motor			根据电机			
	D21	motor			根据电机			motor			根据电机			motor			根据电机			motor			根据电机			motor			根据电机			
	D31	motor			根据电机			motor			根据电机			motor			根据电机			motor			根据电机			motor			根据电机			
	D51	motor			根据电机			motor			根据电机			motor			根据电机			motor			根据电机			motor			根据电机			
	L41	motor			根据电机			motor			根据电机			motor			根据电机			motor			根据电机			motor			根据电机			
L51	motor			根据电机			motor			根据电机			motor			根据电机			motor			根据电机			motor			根据电机				
L61	motor			根据电机			motor			根据电机			motor			根据电机			motor			根据电机			motor			根据电机				

(1) dimensions refer to the mounted motor-type, the size can be changed
(2) dimensions refer to the frame of the boxes, the size can be changed

(1) 这些参数都与所配电机的型号有关, 这些尺寸可以有变化
(2) 这些参数与减速机内部结构有关, 这些尺寸可以有变化



PL(F)/WPL(F)系列精密行星减速机

PF40-PF215-OP2 motor mounting dimensions
PF40-PF215-OP2 电机联接型式外形安装尺寸

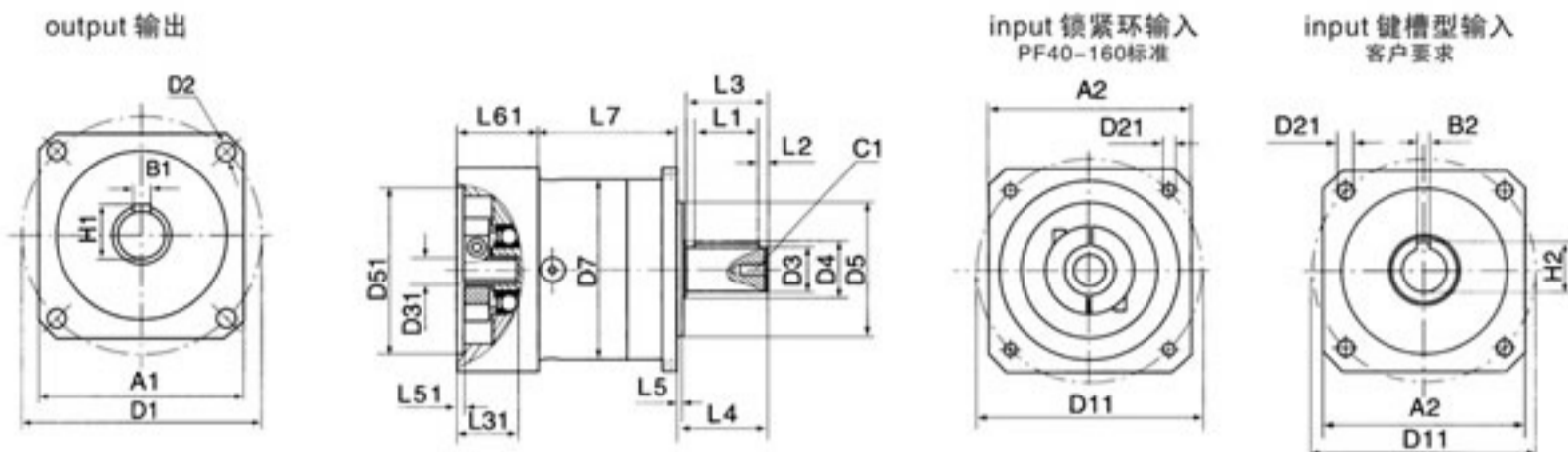

Other shaft 用户可选择的输出类型

output shaft 实轴	S1	Shaft 光轴	S2	shaft with key 单键轴	S3	splined shaft 花键轴	St	special shaft 特殊轴
								According to customers 用户要求制作
output hollow 孔轴	k1	Hollow 光内孔(外配胀紧套)	k2	hollow with key 单键内孔	k3	splined hollow 花键内孔	kt	special hollow 特殊孔
								According to customers 用户要求制作

Type Stage 型号段数	PF40			PF50			PF60			PF70			PF80			PF90			PF115			PF130			PF142			PF215				
	1	2	3	1	2	3	1	2	3	1	2	3	1	2	3	1	2	3	1	2	3	1	2	3	1	2	3	1	2	3		
output/输出端尺寸	A1	45			55			60			75			90			95			120			145			175			215			
	B1	3			4			5			5			6			6			8			10			12			14			
	C1	M4×10			M4×10			M5×12			M5×12			M6×16			M8×19			M10×22			M12×25			M12×25			M12×42			
	H1	11.2			13.5			16			18			22.5			24.5			28			35			43			53.5			
	D1	Φ	50			60			70			85			100			110			130			160			185			235		
	D2	4×	Φ3.5			Φ4.5			Φ5.5			Φ5.5			Φ6.5			Φ6.5			Φ8.5			Φ11			Φ11			Φ13.5		
	D3	Φh6	10			12			14			16			20			22			25			32			40			50		
	D4	Φ	12			15			17			20			25			25			35			40			60			65		
	D5	Φh7	26			45			50			50			80			85			110			120			130			180		
	D7	Φ	40			50			60			70			80			90			115			140			162			205		
	L1	15			14			25			25			25			25			40			55			65			70			
	L2	2.5			2.5			2.5			3			5			5			5			6			7.5			7.5			
	L3	23			18			30			28			36			36			50			70			80			82			
	L4	26			24.5			35			35			40			46			55			75			87			90			
	L5	2			4			3			5			3			5			4			5			5			6			
L7 ⁽²⁾	38.5	53	67.5	33.5	49.5	65.5	48	67	86	47.5	67.5	87.5	65	86.5	110.5	55	77	101	74	104	134.5	85	123.5	162	95	134.5	173.5	137	176.5	216		
input ⁽¹⁾ /输入端尺寸 ⁽¹⁾	A2	motor			根据电机			motor			根据电机			motor			根据电机			motor			根据电机			motor			根据电机			
	B2	motor			根据电机			motor			根据电机			motor			根据电机			motor			根据电机			motor			根据电机			
	H2	motor			根据电机			motor			根据电机			motor			根据电机			motor			根据电机			motor			根据电机			
	D11	motor			根据电机			motor			根据电机			motor			根据电机			motor			根据电机			motor			根据电机			
	D21	motor			根据电机			motor			根据电机			motor			根据电机			motor			根据电机			motor			根据电机			
	D31	motor			根据电机			motor			根据电机			motor			根据电机			motor			根据电机			motor			根据电机			
	D51	motor			根据电机			motor			根据电机			motor			根据电机			motor			根据电机			motor			根据电机			
	L41	motor			根据电机			motor			根据电机			motor			根据电机			motor			根据电机			motor			根据电机			
	L51	motor			根据电机			motor			根据电机			motor			根据电机			motor			根据电机			motor			根据电机			
L61	motor			根据电机			motor			根据电机			motor			根据电机			motor			根据电机			motor			根据电机				

(1) dimensions refer to the mounted motor-type, the size can be changed
(2) dimensions refer to the frame of the boxes, the size can be changed

(1) 这些参数都与所配电机的型号有关, 这些尺寸可以有变化
(2) 这些参数与减速机内部结构有关, 这些尺寸可以有变化

PL(F)/WPL(F)系列精密行星减速机



PL40-PL200-OP2 motor mounting dimensions
PL40-PL200-OP2 电机联接型式外形安装尺寸

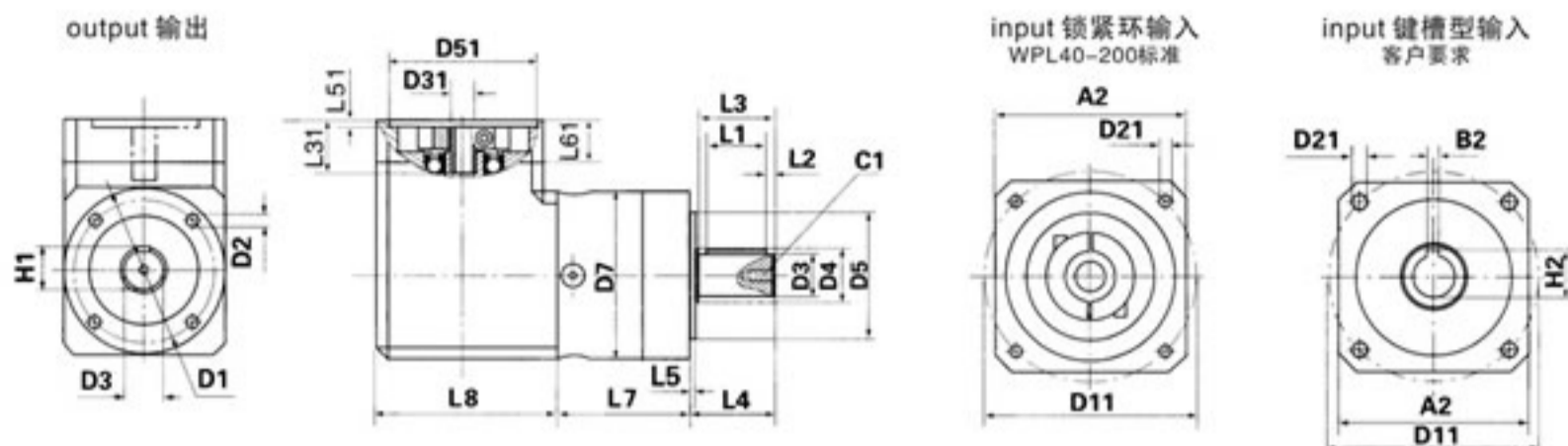

Other shaft 用户可选择的输出类型

output shaft 实轴	S1	Shaft 光轴	S2	shaft with key 单键轴	S3	splined shaft 花键轴	St	special shaft 特殊轴
	According to customers 用户要求制作							
output hollow 孔轴	k1	Hollow 光内孔(外配胀紧套)	k2	hollow with key 单键内孔	k3	splined hollow 花键内孔	kt	special hollow 特殊孔
	According to customers 用户要求制作							

Type Stage 型号段数	WPL40			WPL50			WPL60			WPL70			WPL80			WPL90			WPL120			WPL140			WPL160			WPL200			
	1	2	3	1	2	3	1	2	3	1	2	3	1	2	3	1	2	3	1	2	3	1	2	3	1	2	3	1	2	3	
B1	3			4			5			5			6			6			8			10			12			14			
C1	M4×10			M4×10			M5×12			M5×12			M6×16			M8×19			M10×22			M12×25			M12×25			M20×42			
H1	11.2			13.5			16			18			22.5			24.5			28			35			43			53.5			
D1	Φ	34		44		52		62		70		80		80		100		120		120		145		184							
D2	4x	M4×6		M4×9		M5×8		M5×10		M6×10		M6×12		M10×16		M10×16		M12×20		M12×20		M12×22									
D3	h7	10		12		14		16		20		22		25		32		40		40		50									
D4		12		15		17		20		25		25		35		45		55		55		110									
D5	h7	26		35		40		52		60		68		80		100		130		130		160									
D7		40		50		60		70		80		90		115		140		162		162		205									
L1		16		14		25		25		25		25		40		55		65		65		70									
L2		2.5		2.5		2.5		3		5		5		5		6		8		8		7.5									
L3		23		18		30		28		36		36		50		70		80		80		82									
L4		26		24.5		35		35		40		46		55		75		85		85		90									
L5		2		4		3		5		3		5		4		5		5		5		6									
L7 ⁽²⁾		38.5	53	67.5	33.5	49.5	65.5	48	67	86	47.5	67.5	87.5	65	86.5	110.5	55	77	101	74	104	134.5	85	123.5	162	95	134.5	173.5	137	176.5	216
L8		49		49		75		75		103.6		103.6		125.5		140		151.2		151.2		205									
A2	According to motor 根据电机尺寸制作	motor		根据电机		motor		根据电机		motor		根据电机		motor		根据电机		motor		根据电机		motor		根据电机							
B2		motor		根据电机		motor		根据电机		motor		根据电机		motor		根据电机		motor		根据电机		motor		根据电机							
H2		motor		根据电机		motor		根据电机		motor		根据电机		motor		根据电机		motor		根据电机		motor		根据电机							
D11		motor		根据电机		motor		根据电机		motor		根据电机		motor		根据电机		motor		根据电机		motor		根据电机							
D21		motor		根据电机		motor		根据电机		motor		根据电机		motor		根据电机		motor		根据电机		motor		根据电机							
D31		motor		根据电机		motor		根据电机		motor		根据电机		motor		根据电机		motor		根据电机		motor		根据电机							
D51		motor		根据电机		motor		根据电机		motor		根据电机		motor		根据电机		motor		根据电机		motor		根据电机							
L31		motor		根据电机		motor		根据电机		motor		根据电机		motor		根据电机		motor		根据电机		motor		根据电机							
L51		motor		根据电机		motor		根据电机		motor		根据电机		motor		根据电机		motor		根据电机		motor		根据电机							
L61		motor		根据电机		motor		根据电机		motor		根据电机		motor		根据电机		motor		根据电机		motor		根据电机							

(1) dimensions refer to the mounted motor-type, the size can be changed
(2) dimensions refer to the frame of the boxes, the size can be changed

(1) 这些参数都与所配电机的型号有关, 这些尺寸可以有变化
(2) 这些参数与减速机内部结构有关, 这些尺寸可以有变化



PL(F)/WPL(F)系列精密行星减速机

WPF40-PF215-OP2 motor mounting dimensions
WPF40-WPF215-OP2 电机联接型式外形安装尺寸

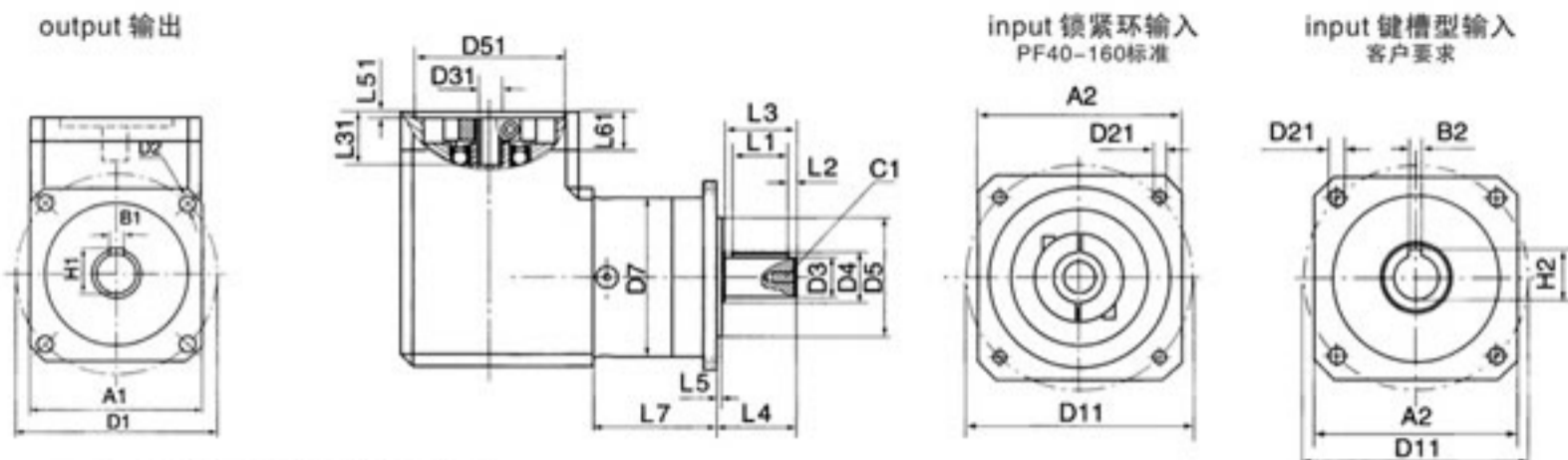

Other shaft 用户可选择的输出类型

output shaft 实轴	S1	Shaft 光轴	S2	shaft with key 单键轴	S3	splined shaft 花键轴	St	special shaft 特殊轴
								According to customers 用户要求制作
output hollow 孔轴	k1	Hollow 光内孔(外配胀紧套)	k2	hollow with key 单键内孔	k3	splined hollow 花键内孔	kt	special hollow 特殊孔
								According to customers 用户要求制作

Type Stage 型号段数	WPF40			WPF50			WPF60			WPF70			WPF80			WPF90			WPF115			WPF130			WPF142			WPF215				
	1	2	3	1	2	3	1	2	3	1	2	3	1	2	3	1	2	3	1	2	3	1	2	3	1	2	3	1	2	3		
output/输出端尺寸	A1	45			55			60			75			90			95			120			145			175			215			
	B1	3			4			5			5			6			6			8			10			12			14			
	C1	M4×10			M4×10			M5×12			M5×12			M6×16			M8×19			M10×22			M12×25			M12×25			M20×42			
	H1	11.2			13.5			16			18			22.5			24.5			28			35			43			53.5			
	D1	Φ	50			60			70			85			100			110			130			160			185			235		
	D2	4×Φ	Φ3.5			Φ4.5			Φ5.5			Φ5.5			Φ6.5			Φ6.5			8.5			11			11			13.5		
	D3	Φh6	10			12			14			16			20			22			25			32			40			50		
	D4	Φ	12			15			17			20			25			25			35			40			60			65		
	D5	Φh7	26			45			50			50			80			85			110			120			130			180		
	D7		40			50			60			70			80			90			115			140			162			205		
	L1		15			14			25			25			25			25			40			55			65			70		
	L2		2.5			2.5			2.5			3			5			5			5			6			8			7.5		
	L3		23			18			30			28			36			36			50			70			80			82		
	L4		26			24.5			35			35			40			46			55			75			87			90		
	L5		2			4			3			5			3			5			4			5			5			6		
L7 ⁽²⁾		38.5	53	67.5	33.5	49.5	65.5	48	67	86	47.5	67.5	87.5	65	86.5	110.5	55	77	101	74	104	134.5	85	123.5	162	95	134.5	173.5	137	176.5	216	
input ⁽¹⁾ /输入端尺寸 ⁽¹⁾	A2	motor			根据电机			motor			根据电机			motor			根据电机			motor			根据电机			motor			根据电机			
	B2	motor			根据电机			motor			根据电机			motor			根据电机			motor			根据电机			motor			根据电机			
	H2	motor			根据电机			motor			根据电机			motor			根据电机			motor			根据电机			motor			根据电机			
	D11	motor			根据电机			motor			根据电机			motor			根据电机			motor			根据电机			motor			根据电机			
	D21	motor			根据电机			motor			根据电机			motor			根据电机			motor			根据电机			motor			根据电机			
	D31	motor			根据电机			motor			根据电机			motor			根据电机			motor			根据电机			motor			根据电机			
	D51	motor			根据电机			motor			根据电机			motor			根据电机			motor			根据电机			motor			根据电机			
	L41	motor			根据电机			motor			根据电机			motor			根据电机			motor			根据电机			motor			根据电机			
	L51	motor			根据电机			motor			根据电机			motor			根据电机			motor			根据电机			motor			根据电机			
	L61	motor			根据电机			motor			根据电机			motor			根据电机			motor			根据电机			motor			根据电机			

(1) dimensions refer to the mounted motor-type, the size can be changed
(2) dimensions refer to the frame of the boxes, the size can be changed

(1) 这些参数都与所配电机的型号有关, 这些尺寸可以有变化
(2) 这些参数与减速机内部结构有关, 这些尺寸可以有变化